

GRAPHITE RUPTURE DISC SERIES - GD, GDI, GDV, GDL, GDT, GDHT, GDIHT, GDVHT

DESCRIPTION

Fike Graphite Series Rupture Discs are simple and reliable pressure relief devices. Our Graphite Discs are manufactured to be virtually impermeable which results in excellent corrosion resistance to most acids and corrosive media, resistance to temperature and long term stability. The discs install directly between pipe flanges eliminating the need for a holder and have a variety of gasket material and attachment options.

Fike graphite rupture discs are easily customizable to the customer's exact specifications. Each disc is additionally offered with a "Zero" manufacturing range as the standard allowing each lot of graphite rupture discs to be marked with the requested burst pressure, at the requested temperature. Maximum variation from the marked pressure is expressed as the rupture tolerance in accordance to the table shown below:



RUPTURE TOLERANCE

Specified Burst Pressure	Rupture Tolerance
Above 40 PSIG (2.76 BARG)	± 5%
15 PSIG (1.03 BARG) - 40 PSIG (2.76 BARG)	± 2 PSIG (.14 BARG)
5 PSIG (.34 BARG) < 15 PSIG (1.03 BARG)	± 1 PSIG (.07 BARG)
> 1 PSIG (.07 BARG) < 5 PSIG (.34 BARG)	± .75 PSIG (.05 BARG)
≤ 1 PSIG (.07 BARG)	- 0/+ .75 PSIG (.05 BARG)

OPTIONAL PERFORMANCE TOLERANCES AVAILABLE

Performance Tolerance	Tolerance*
Special Min/Max	Included
± 5% Performance Tolerance	± 5% of Specified burst pressure
± 10% Performance Tolerance	± 10% of Specified burst pressure

*Performance tolerances can be ordered if total tolerance is greater or equal to standard rupture tolerance for the specified burst pressure range.

Form No. R.1.40.01-8

GD SERIES

The GD Series meets most processing applications. The disc is available in diameters from 1/2 to 24 inches at burst pressures from .25 to 150 PSIG (.02 to 10.34 BARG) for specified temperatures up to 430°F (221°C) without insulation.

GDV SERIES (NOT SHOWN)

The GDV Series rupture disc is intended for use in vacuum service applications. The GDV rupture disc utilizes one of four vacuum support types and is required for burst pressures less than 20 PSIG (1.38 BARG) in full vacuum conditions for specified temperatures up to 430°F (221°C) without insulation. For required vacuum support types see reference guide on page 4.

GDI SERIES

GDI Series Discs are designed to fit standard ASME Class 150 and Class 300 flanges. Inverted discs have the same temperature characteristics as GD discs but offer higher burst pressures.

GDL SERIES

GDL Discs extend corrosion resistance to highly oxidizing agents, halogens and virtually all other corrosives, except free fluorine. A liner is used as a permanent barrier on the service side of the disc. PTFE is the standard liner material but others are available upon request. Additionally, these discs are suitable for specified temperatures up to 430°F without insulation.

GDT SERIES (NOT SHOWN)

GDT Discs have two ratings, one for overpressure and the other for vacuum protection. GDT discs have a temperature range of -290°F to 430°F (-179°C to 221°C) and are most commonly used on single entry storage vessels or manifold vents.

GDHT, GDIHT, GDVHT SERIES

High temperature rated discs are available in GD, GDV and GDI styles to accommodate specified temperatures up to 700°F. They are furnished as an attached unit as shown because the nameplate rating of the disc must be established at the cold face temperature of the insulation. GDHT, GDVHT, GDIHT discs utilize fibrous silica and alumina which is not suitable with liquid applications, and can be attacked by hydrofluoric and phosphoric acids and concentrated alkalis.

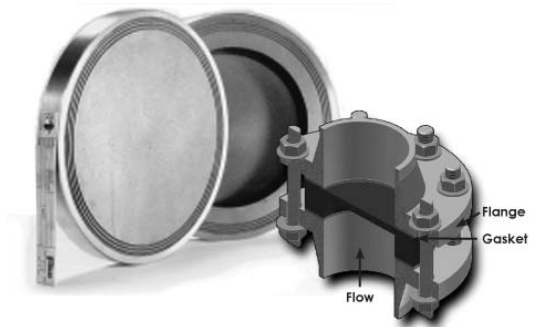

GD Series

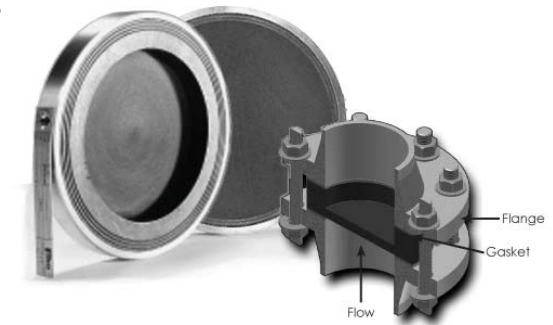

GDI Series

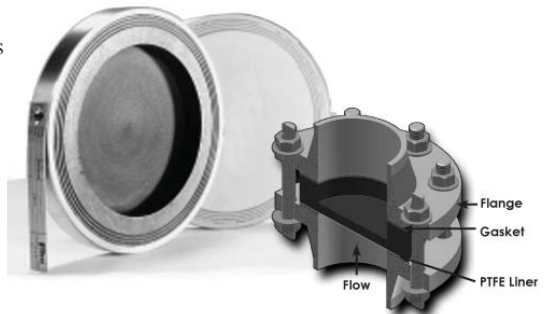

GDL Series

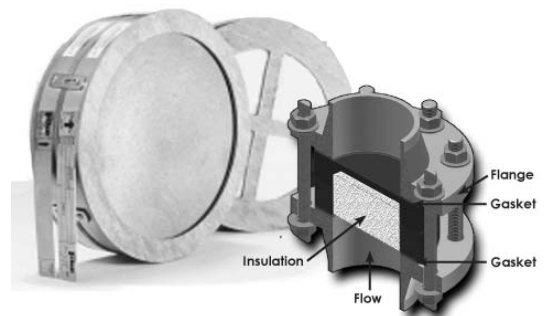

GDHT Series

Special Considerations:

- 1) Carbon steel or stainless steel armoring is optional for all graphite rupture discs. For added safety and reliable performance, armoring is strongly recommended for higher pressures.
- 2) Carbon steel armoring is required on the following discs:
 - a) All discs for ANSI Class 300 flanges
 - b) All discs rated above 338°F
 - c) For toxic or flammable environments
 - d) All high temperature rated discs
 - e) GDT Series discs
 - f) All discs above the following pressure ratings:





Disc Size	Burst Pressure @ 72°F(22°C)
1/2 - 3 inch	150 PSIG (10.34 BARG)
4 inch	100 PSIG (6.89 BARG)
6 - 10 inch	75 PSIG (5.17 BARG)
12-24 inch	50 PSIG (3.45 BARG)

- 3) The GDHT, GDIHT and GDVHT models are provided with compressed fiber gaskets standard for temperatures above 430°F (221°C)
- 4) Attached and loose gaskets are available in the following materials:

Standard Gasket Materials	Thickness (in.)	Max Temp
Compressed Fiber (Non-Asbestos)	1/8	400°F (204°C)
Neoprene	1/8	212°F (100°C)
PTFE (Solid)	1/8	450°F (232°C)
PTFE (Envelope)	1/8	450°F (232°C)

Consult factory for other available gasket materials.

- 5) PTFE Coatings are available on the process side, downstream side, or both sides. An additional special sealing process is also available to improve leak tightness when required. Consult Fike for more information.
- 6) All graphite discs will fragment upon burst.
- 7) GD Series standard burst pressures for ANSI 150 flanges sizes 1 to 8 inch are: 10, 15, 20, 25, 30, 40, 50, 75, 100, 125, 150 PSIG @ 72°F (.69, 1.03, 1.38, 1.72, 2.07, 2.76, 3.45, 5.17, 6.89, 8.62, 10.34 BARG @ 22°C). Sizes 6" and 8" for ANSI 150 flanges sizes will be supplied as a GDI. The burst pressures are: 125, 150 PSIG @ 72°F (8.62, 10.34 BARG @ 22°C).
- 8) GDI Series standard burst pressures for ANSI 300 flanges sizes 1 to 3 inch are: 175, 200, 225, 250, 275, 300 PSIG @ 72°F (12.07, 13.79, 15.51, 17.24, 18.96, 20.68 BARG @ 22°C).
- 9) ASME UD Certification is available for the following disc models: GD, GDV, GDI, GDL
- 10) CE Certification is available for the following disc models: GD, GDV, GDI, GDL, GDT
- 11) Integral Burst Indication is also available for all series graphite discs in sizes 1" and larger and comes installed by the manufacturer on the disc with gaskets attached and ready for installation. Acceptable gaskets for use with the integral burst indicator include Compressed Fiber, TFE, and Gylon.

Performance Attributes		Process Media	
Operating Ratio*	Vacuum Resistant	Liquid	Vapor/Gas
			
90%	yes	yes	yes

* Operating ratio varies based on burst pressure and heavy cyclic duty

GD, GDV, GDHT, GDVHT SERIES BURST PRESSURES & DIMENSIONS

Fits Class 150 ASME Flanges									
IN	DN	Diameter (inches)		Thickness (inches)*		Burst Pressures		Gasket I.D.	Gasket O.D.
		I.D.	O.D.	GD, GDV	GDHT, GDVHT	Min. PSIG (BARG)	Max. PSIG (BARG)		
1/2	15	.622	1 3/4	5/8	1 3/4	25 (1.72)	150 (10.34)	7/8	1 3/4
3/4	20	.824	2 1/8	5/8	1 3/4	25 (1.72)	150 (10.34)	1 1/8	2 1/8
1	25	1	2 1/2	7/8	2 1/4	10 (.69)	150 (10.34)	1 5/16	2 1/2
1 1/2	40	1 1/2	3 1/4	7/8	2 1/4	7 (.48)	150 (10.34)	1 29/32	3 1/4
2	50	2	4	7/8	2 1/4	3 (.21)	150 (10.34)	2 1/2	4
3	80	3	5 1/4	7/8	2 1/4	2 (.14)	150 (10.34)	3 3/4	5 1/4
4	100	4	6 3/4	7/8	2 1/4	1.50 (.10)	150 (10.34)	5	6 3/4
6	150	6	8 5/8	7/8	2 1/4	1 (.07)	100 (6.89)	7 1/8	8 5/8
8	200	8	10 7/8	1 1/8	2 3/4	.50 (.03)	100 (6.89)	8 7/8	10 7/8
10	250	10	13 1/4	1 1/2	3 3/8	.25 (.02)	100 (6.89)	11 5/8	13 1/4
12	300	12	16	2	4 3/8	.25 (.02)	75 (5.17)	13 3/4	16
14	350	13 1/4	17 5/8	2 1/4	4 7/8	.25 (.02)	50 (3.45)	14 1/2	17 5/8
16	400	15 1/4	20 1/8	2 1/2	5 3/8	.25 (.02)	50 (3.45)	17	20 1/8
18	450	17 1/4	21 1/2	2 3/4	5 7/8	.25 (.02)	50 (3.45)	19 1/2	21 1/2
20	500	19 1/4	23 3/4	3	6 3/8	.25 (.02)	40 (2.76)	21 3/4	23 3/4
24	600	23 1/4	28 1/8	3	6 3/8	.25 (.02)	25 (1.72)	25	28 1/8

* GD and GDV disc thicknesses do not include gaskets. GDHT and GDVHT disc thicknesses include all gaskets.

GDV REQUIRED VACUUM SUPPORT GUIDE*

Size	Burst Pressure	Support Type
1 inch	below 20 PSIG (1.38 BARG)	Ring
1 1/2 inch	below 20 PSIG (1.38 BARG)	Bar
2 - 14 inch	9 to 19 PSIG (.62 to 1.31 BARG)	Bar
2 - 14 inch	5 to 8 PSIG (.34 to .55 BARG)	Cross
2 - 14 inch	< 5 PSIG (.34 BARG)	Plate

* GDV discs are required for all burst pressures under 20 PSIG (1.38 BARG) for full vacuum service. Not available in 1/2 and 3/4 inch sizes
Consult factory for sizes larger than 14 inch.

GDI, GDL* & GDIHT SERIES BURST PRESSURES & DIMENSIONS

Fits Class 150 ASME Flanges										
IN	DN	Diameter (inches)		Thickness (inches)**		Burst Pressures PSIG (BARG)			Gasket I.D.	Gasket O.D.
		I.D.	O.D.	GDI, GDL	GDIHT	GDI, GDIHT Min. PSIG (BARG)	GDL Min. PSIG (BARG)	Max. PSIG (BARG)		
1/2	15	.622	1.34	5/8	1 3/4	25 (1.72)	25 (1.72)	>1000 (68.95)	7/8	1/34
3/4	20	.824	2 1/8	5/8	1 3/4	25 (1.72)	25 (1.72)	>1000 (68.95)	1 1/8	2 1/8
1	25	1	2 1/2	7/8	2 1/4	10 (.69)	10 (.69)	>1000 (68.95)	1 5/16	2 1/2
1 1/2	40	1 1/2	3 1/4	7/8	2 1/4	7 (.48)	7 (.48)	1000 (68.95)	1 29/32	3 1/4
2	50	2	4	7/8	2 1/4	3 (.21)	3 (.21)	300 (20.68)	2 1/2	4
3	80	3	5 1/4	7/8	2 1/4	2 (.14)	2 (.14)	300 (20.68)	3 3/4	5 1/4
4	100	4	6 3/4	7/8	2 1/4	1.5 (.10)	1.5 (.10)	250 (17.24)	5	6 3/4
6	150	6	8 5/8	7/8	2 1/4	1 (.07)	1 (.07)	170 (11.72)	7 1/8	8 5/8
8	200	8	10 7/8	1 1/8	2 3/4	.50 (.03)	.75 (.05)	170 (11.72)	8 7/8	10 7/8
10	250	10	13 1/4	1 1/2	3 3/8	.25 (.02)	.50 (.03)	150 (10.34)	11 5/8	13 1/4
12	300	12	16	2	4 3/8	.25 (.02)	.50 (.03)	150 (10.34)	13 3/4	16
14	350	13 1/4	17 5/8	2 1/4	4 7/8	.25 (.02)	.50 (.03)	150 (10.34)	14 1/2	17 5/8
16	400	15 1/4	20 1/8	2 1/2	5 3/8	.25 (.02)	.50 (.03)	150 (10.34)	17	20 1/8
18	450	17 1/4	21 1/2	2 3/4	5 7/8	.25 (.02)	.50 (.03)	<150 (10.34)	19 1/2	21 1/2
20	500	19 1/4	23 3/4	3	6 3/8	.25 (.02)	.50 (.03)	<150 (10.34)	21 3/4	23 3/4
24	600	23 1/4	28 1/8	3	6 3/8	.25 (.02)	.50 (.03)	<150 (10.34)	25	28 1/8
Fits Class 300 ASME Flanges										
1/2	15	.622	2	5/8	1 3/4	25 (1.72)	25 (1.72)	>1000 (68.95)	7/8	2
3/4	20	.824	2 1/2	5/8	1 3/4	25 (1.72)	25 (1.72)	>1000 (68.95)	1 1/8	2 1/2
1	25	1	2 3/4	1	2 1/2	10 (.69)	110 (.69)	>1000 (68.95)	1 5/16	2 3/4
1 1/2	40	1 1/2	3 5/8	1	2 1/2	7 (.48)	7 (.48)	1000 (68.95)	1 29/32	3 5/8
2	50	2	4 1/4	1	2 1/2	3 (.21)	3 (.21)	500 (34.47)	2 1/2	4 1/4
3	80	3	5 3/4	1 1/4	3	2 (.14)	2 (.14)	500 (34.47)	3 3/4	5 3/4
4	100	4	7	1 1/4	3	1.50 (.10)	1.50 (.10)	500 (34.47)	5	7
6	150	6	9 3/4	1 3/4	4	1 (.07)	1 (.07)	450 (31.03)	7 1/8	9 3/4
8	200	8	12	2 1/4	5	.50 (.03)	.75 (.05)	450 (31.03)	8 7/8	12

* GDL Disc are supplied standard with a PTFE liner. FEP, PFA, KYNAR® and Halar® are available upon request only.

** GDI and GDL disc thicknesses do not include gaskets. GDIHT disc thicknesses include all gaskets.

Note: External Vacuum supports are available for the GDL model. ASME not available with external vacuum support configuration. Consult factory for more information.

GDT SERIES BURST PRESSURES & DIMENSIONS

IN	DN	Disk Dimensions			Min. PSIG (BARG)
		Diameter (inches)		Thickness (inches)*	
		I.D.	O.D.		
1 1/2	40	1 1/2	3 1/4	1 1/8	7 (.48)
2	50	2	4	1 1/8	3 (.21)
3	80	3	5 1/4	1 1/8	2 (.14)
4	100	4	6 3/4	1 1/8	1.5 (.10)
6	150	6	8 5/8	1 1/8	1 (.07)
8	200	8	10 7/8	1 3/8	.50 (.03)
10	250	10	13 1/4	1 3/4	.25 (.02)
12	300	12	16	2 1/4	.25 (.02)
14	350	13 1/4	17 5/8	2 1/2	.25 (.02)
16	400	15 1/4	20 1/8	2 3/4	.25 (.02)
18	450	17 1/4	21 1/2	3	.25 (.02)
20	500	19 1/4	23 3/4	3 1/4	.25 (.02)
24	600	23 1/4	28 1/8	3 1/4	.25 (.02)

* Disc thickness includes all gaskets.

Notes: A minimum differential of 10 PSIG (.69 BARG) is required between burst pressures. For other burst pressure combinations consult factory.

HOW TO SPECIFY

To order the Graphite Rupture Disc, please specify the following as a minimum

Previous Lot Number:	
OR	
Model:	
Size:	
Flange Rating:	ANSI 150, 300, or other
Burst Pressure:	@ (Temperature)
Accessories (specify):	Gaskets Armoring TFE Coating Liner
Gasket Attached:	Yes / No
Gasket Material:	
ASME or CE Certification:	

CERTIFICATIONS



ASME Authorized
Specify When Ordering



Copyright © Fike Corporation All Rights Reserved.
Form No. R.1.40.01-8 March 2012 Specifications are subject to change without notice.